

Tel: UK: +44 (0)208 133 9203
+44 (0)745 238 4267
USA: +1 (206) 866 5730
AUSTRALIA: +61 (08) 6102 0192
NIGERIA: +234 (0) 703 883 3437
+234 (0) 816 265 1068
Vmail & Fax:- +44 (0) 207 681 1505
Skype:- alunow & nigeriashipbuilding

**AluTug to be based on known designs developed in conjunction with the
Naval Architects concerned to meet client requirements
Built at our shipyards in Nigeria, UK, or Turkey**

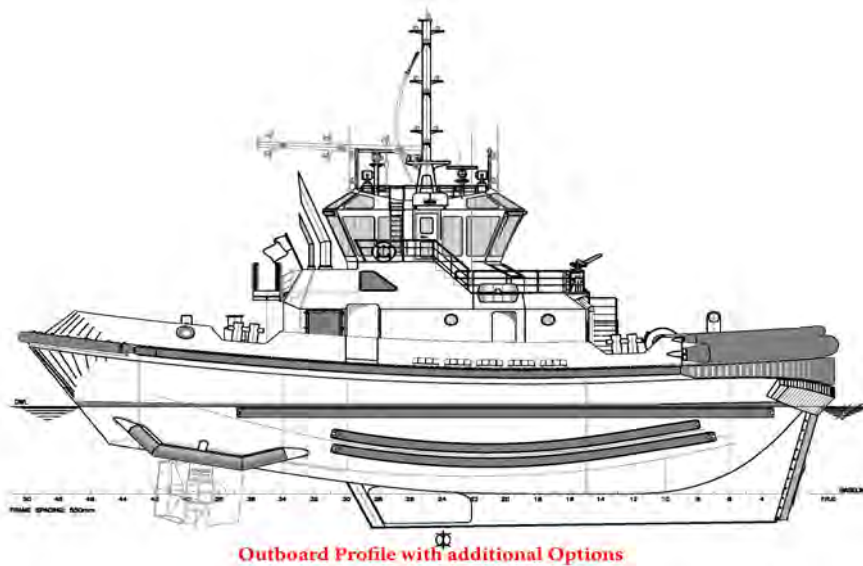

The award-winning Z-Tech™ Class tugs is reported to be initially developed specifically for PSA Marine of Singapore. The design incorporates the best handling and operational characteristics of both Z-drive tractor tugs and Azimuthing Stern-Drive (ASD) or "pusher" tugs. The Z-Tech™ class tugs are designed primarily for operation in major ports and marine terminals.



The design of the Z-Tech™ tug emphasizes the safe and capable operation of ship-handling operations with large ships, particularly those with extreme flares.

- Note:-
- 1) Proprietary design information and drawings supplied by shipyard concerned and is the property of the Naval Architect concerned.
 - 2) Z-Tech a registered trademark of Robert Allan Ltd..
 - 3) Information found here has been sourced from Public Sites or from companies concerned and is supplied for your information. Interested parties are advised to carry-out their own research and due-diligence.



The Z-Tech™ design offers omni-directional performance; speed and Bollard Pull astern are almost equal to that going ahead.

Suite 405, Henry House, 275 New North Road, England, UK

Email:- enquiries@aluminumnow.com Web:- www.aluminumnow.com , www.aluminumnowturkey.com
www.nigeriashipbuilding.com, www.green-tug.com, www.patrolboats-africa.com, www.aluminumnownigeria.com

The most unique feature of the Z-Tech™ tug is the relationship of sheer distribution to the working deck areas, and the location of the deckhouse and wheelhouse in relation to the "working end". Emphasizing the need to work in either a push or pull mode under the flared ends of large container ships, LNG carriers and car carriers, the Z-Tech™ has a flat forward sheer, and a wide, heavily fendered bow.

The wheelhouse is set well aft and inboard, offering excellent visibility over the entire working deck and to the sides of the tug, ensuring that there is almost zero risk of contact with a ship when working. With the low bow, the tug is then expected to make transit or open water voyages stern-first in the "tractor mode". In this configuration, the Z-Tech™ tug then can also function efficiently with only one winch, located for maximum efficiency for both ship-handling and towing operations. To ensure good sea-keeping capability, the stern has a strong vertical sheer, and is much more rounded than in a typical tug, presenting a "sea-going" stern. The underwater hull however is essentially identical to that of other ASD tugs designed by Robert Allan Ltd.

The Z-Tech™ tugs are classified according to their Bollard Pull, however are adaptable to a range of powers and engine types in each size.

For more in depth information on Z-Tech and other designs please contact us at enquiries@aluminumnow.com

| | |
|--------------------------------------|---|
| Class as required | LR +100A1 + LMC or ABS,A1 AMS, Towing Vessel, Unrestricted Navigation Service, Fi-Fi 1 |
| Designer | Robert Allan Ltd. |
| BHP | Approx. 5,000 |
| Length overall, metres | 27.5 |
| Length water line, metres | 24.8 |
| Beam overall, metres | 11.6 |
| Depth moulded, metres | 5.0 |
| Summer Draft, metres | 3.5 |
| Maximum Draught, metres | 5.0 |
| Propulsion | To meet client's requirements |
| Conventional | Two(2) Caterpillar 3516C, MTU 16V4000 or equal, main engines rated at 2500 BHP each or similar, Aqua - Manoeuver, or equal, azimuthing drives with Centa or similar straight line carbon fiber shaft and couplings. Slip clutch or CPP units fitted to suit Fi-Fi system. |
| Diesel Electric | All electric drive systems, Engtek Manoeuvra E-Pods(ASD), Fi-Fi 1 |
| LNG Electric | All electric drive systems, Engtek Manoeuvra E-Pods(ASD), Fi-Fi 1 |
| Diesel Electric Series Option | As per conventional with inline electric drive |



| | |
|----------------------------------|---|
| Z-Drives | Aqua - Manoeuvre, or equal to suit drive system |
| Hawser winch | Markey machinery, model DEPCF-50 or similar 75 HP electric winch with level wind and auto-tension, render/recover feature, line capacity: 500 ft, 9” synthetic line, 12,000 # pull @ 175 ft/min , 225,000 # brake hold. Optional JonRie Series 200 75 H.P. hydraulic or similar |
| Maximum bollard pull, tonnes | 60 |
| Free running Speed, knots | 12.0 |
| Endurance, nautical miles | 2500 |
| Diesel oil tankage, cubic metres | 96.0 |
| Water tankage, cubic metres | 21.0 |
| Foam/Dispersant tankage | 3.0 cubic metres each |
| Lube oil tankage, cubic metres | 2.9 |
| Fire-fighting system | Fire Fighting Systems (FFS), Stang/Counterfire or equal, Fi-Fi 1 system with deluge protection. Two(2) 1200 m ³ /hr pumps driven from PTO/clutch on main engines or electric drive. |
| Navigational equipment | To meet client’s requirements |
| Anchor Winch | 500# Emergency anchor to comply with Classification requirements deployed by hawser winch. Separate anchor winch can be provided if required. |
| Generators/Switch Board | Eltech Electric, I.P.S. (Industrial Power System) switchboard or similar, (1) 130 kW Perkins, John Deere, Northern Lights or equal or as per drive requirements |
| Crew Accommodation | One(1) Master – One(1) Engineer – Four(4) Crew |

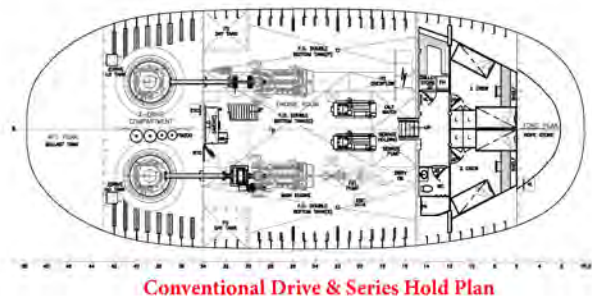

AluTug- RAL Z-Tech 6000



Wheelhouse Plan

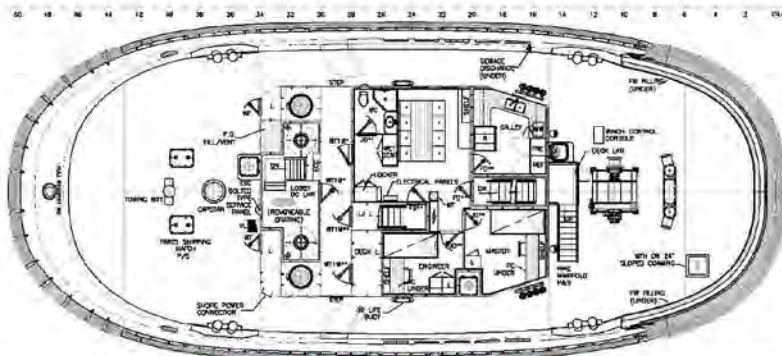
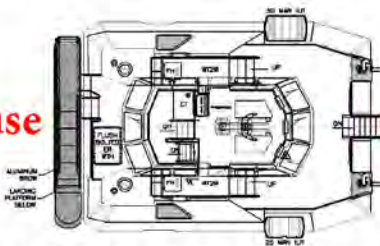

Main Deck Plan

The wheelhouse has Excellent Visibility

Green Tug Concept



AluminumNow Maritime Solutions Ltd. presents our **Green Line option** to be based on a known and trusted tug design with an inherent ability to efficiently regenerate energy normally lost during operations, we believe this features unparalleled economy and environmental compliance extending into the future with the proposed EPA Tier 3 Requirements

The Green line option may obtain savings exceeding 35% in Fuel consumption while providing a more environmentally friendly operation with reduction in emissions.

Greenline, & Greenline Option & Green Tug Concept copyright by AluminumNow

In addition to using Perkins Diesel Generators for the power source another option to consider is LNG.



Perkins LNG Tug Power

4000 Series 4016 61TRS1/2

Spark Ignited Gas Engine - 1042 kWm at 1500 rev/min

Designed to meet the future demands of the market for clean, efficient gas fuelled engines for the power generation industry, the Perkins 401661TRS 16 cylinder spark ignition gas engine offers high performance, dependability and reliability while meeting the increasingly stringent emission requirements of the market.

The 401661TRS is a turbocharged and air to water charged cooled 16cylinder vee form engine designed for operation on natural gas. Particular emphasis on efficiency and emission control together with durability, reliability and exceptional thermal efficiency and reduced whole life costs, make selection of the Perkins 4016-61TRS engine the prime choice at a nominal 1000 kW.



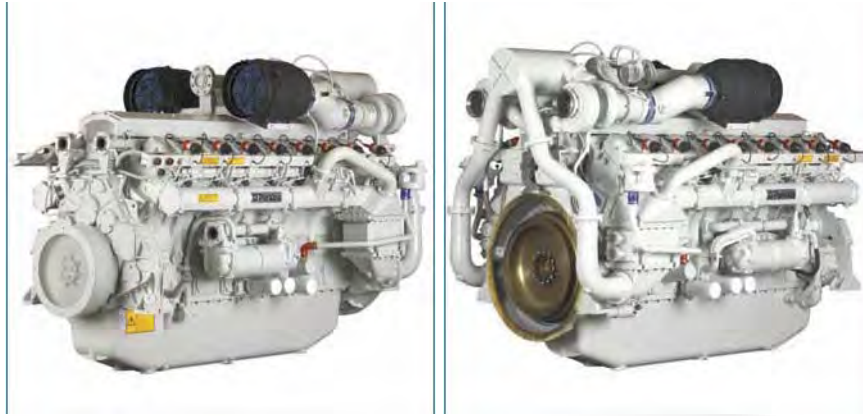

Efficient power

The modern design of the very latest developments in combustion and engineering techniques, to give world beating, fuel efficiencies, economical whole life costs and reliability.

Clean, smooth power

Extensive research in combustion and noise/vibration/harshness have resulted in a smooth, quiet engine. This, combined with the emissions performance makes the 401661TRS more environmentally acceptable in these days of increased concern.

Reliable power

Extended durability and attention to reduced servicing with extended component life add to the benefit of reduced whole life cost. Total after sales service, backed by a network of Perkins Gas Partners with dedicated expertise in service and maintenance of gas engines.

Options

The 401661TRS spark ignited gas engine can be supplied to suit customer requirements as a Gas Electro Unit for power generation or Cogen unit specification for combined heat and power operation.

| Engine Speed (rev/min) | Type of Operation Continuous Operation Power | Gross Engine Power | |
|---------------------------|---|--------------------|------|
| | | kWe | kWm |
| 1500 | TRS1 | 875 | 912 |
| 1500 | TRS2 | 1000 | 1042 |

4000 Series 4016 61TRS1/2

Standard Specification Core engine

- High grade cast iron featuring integral crankcase inspection doors
- Wet type liners in centrifugal cast iron, plateau honed for quick ring bedding and reduced oil consumption
- Forged steel crankshaft
- Forged camshaft - carburized hardened
- High grade cast iron individual cylinder heads, each with four valves per cylinder
- Crankshaft driven gear train for camshaft
- Aluminium alloy piston with advanced bowl design. Three ring pack, gallery (oil) cooled
- Slit cap connecting rods, forged steel with multi-bolt fixing shot peened

Gas/Ignition system

- Air/Fuel mixer with Woodward Tecjet gas injection valve control system; automatic adjustment according to fuel gas characteristics
- Metal braided flexible gas connection
- Individual cylinder ignition coils mounted direct to the spark plugs

Lubrication system

- Gear driven lubricating oil pump, externally mounted
- Spin on, canister type replaceable lubricating oil filters
- Shell and tube type oil coolers, jacket water cooled
- Crankcase closed circuit ventilation system

Cooling system

- Pressurized fresh water jacket water cooling system
- Two stage air to water charge cooler, jacket/secondary water cooled

Air intake system

- Paper element air filter complete with restriction indicator
- Exhaust gas driven turbocharger

Exhaust system

- Dry cast iron exhaust manifolds with heat shields
- Horizontal exhaust outlet

Engine management system

- Full electronic management system, governing to ISO 8528 Part 5
- Class G2 standard
- Engine protection system for high/low coolant temperature and low oil pressure, overspeed, misfire and knock protection
- Customer communication module

Electrical system

- 24 volt electric starter motors

Drive system

- Cast iron flywheel housing SAE 00 and flywheel SAE J620 Size 18
- Viscous type torsional vibration damper
- Engine supports: front and rear feet mounted off the crankcase
- Commercial primer finish

Fuel Consumption

| 100% 75% 50% 25% Continuous baseload rating of: | Cogeneration Unit (gross) TRS1 TRS2 2,51 2,48 2,60 2,58 2,68 2,66 2,75 2,74 | Electro Unit (gross) TRS1 TRS2 2,56 2,53 2,63 2,60 2,70 2,68 2,77 2,76 |
|---|---|---|
|---|---|---|

Packing/Preservation

- All engines are preserved after test running, shrink wrapping and suitable for containerized shipment

General Data

| | |
|-----------------------------------|---|
| Number of cylinders | 16 |
| Cylinder arrangement | 60° Vee |
| Cycle | 4 stroke |
| Induction system | Turbocharged |
| | Two stage charge cooled |
| Combustion system | Spark ignition |
| Cooling system | Water cooled |
| Bore and stroke | 160 x 190 mm |
| Displacement | 61.12 litres |
| Compression ratio | 12:1 |
| Direction of rotation | Anticlockwise, viewed on flywheel |
| Total lubrication system capacity | 286 litres |
| Total coolant capacity | 95 litres |
| Dimensions (electro unit) | Length 3192 mm Width 1737 mm Height 1969 mm |
| Dry weight (electro unit) | 5820 kg |



Driving Technology advances that produce results

AluminumNow in conjunction with **Engtek Manoeuvra Marine Thruster Systems** is working with new and emerging technologies to improve our Electric Thruster and Propulsion product offering.

It is the mission of the *EMS- Thruster Systems* to continually improve the quality, reliability and cost effectiveness of our Thruster Systems, while achieving higher levels of performance.

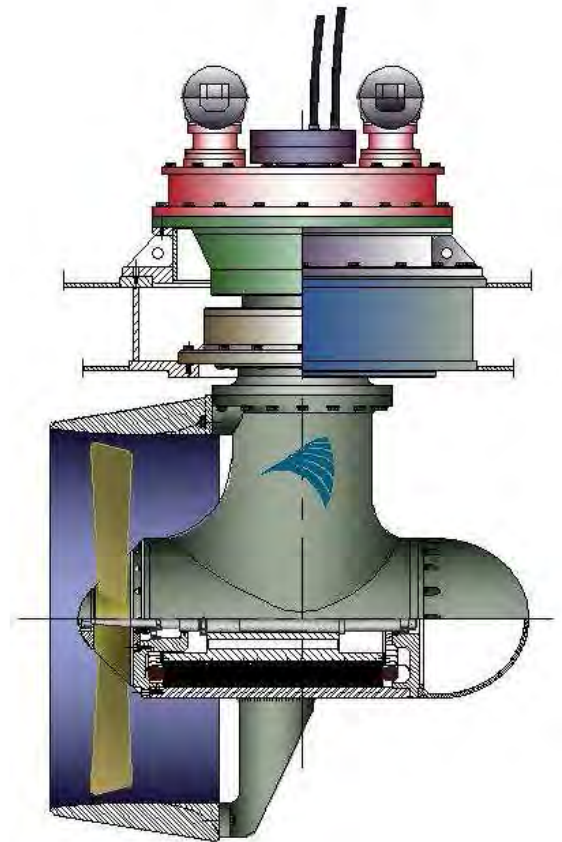
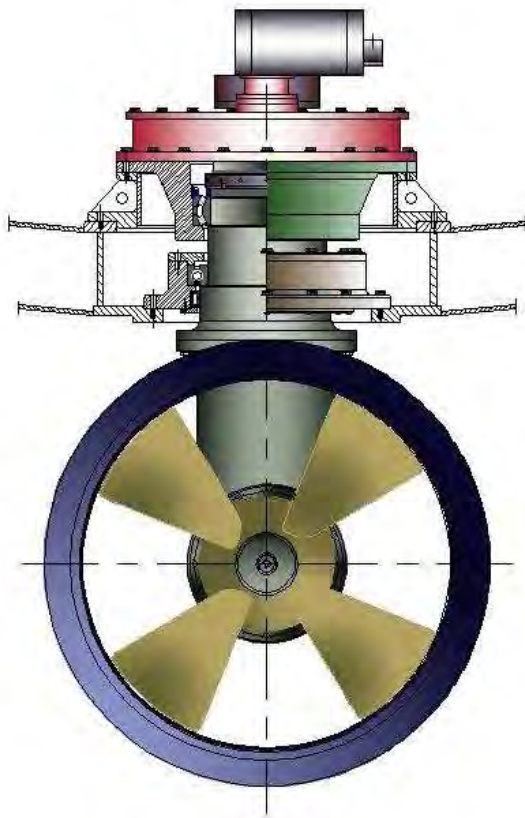
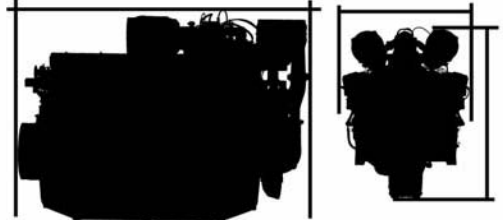

The **E-pod** thruster and propulsion system combines the expertise in propulsion, hydrodynamics and azimuthing thrusters with the experience for electric propulsion drives. In addition to the flexibility in machinery and vessel arrangement offered by electric propulsion drives, the E-Pod system gives improved efficiency and excellent manoeuvrability.

The E-Pod is 360 degrees Rotatable for manoeuvring purposes, or +/- 60 degrees hardover/hardover in transit, by the means of a hydraulically operating steering gear. The main component in the underwater unit is the electric motor; in this case a Permanent magnet synchronous type with brushless excitation and the stator assembly shrink fit in the pod housing.

The propeller is of the fixed pitch type, characterized by low noise and vibration, and can be either delivered with separately bolted blades or cast as a complete monobloc.

A feature with separately bolted blades is that these can be changed more easily in case of damage.

A Plus feature of the design is the ability to remove the unit for service quickly with the tug/ship afloat. Therefore with a spare unit in stock there is no lost time in operation.

For Further Information on the GreenTug Options please contact Richard O J. Naylor at rnaylor@aluminumnow.com

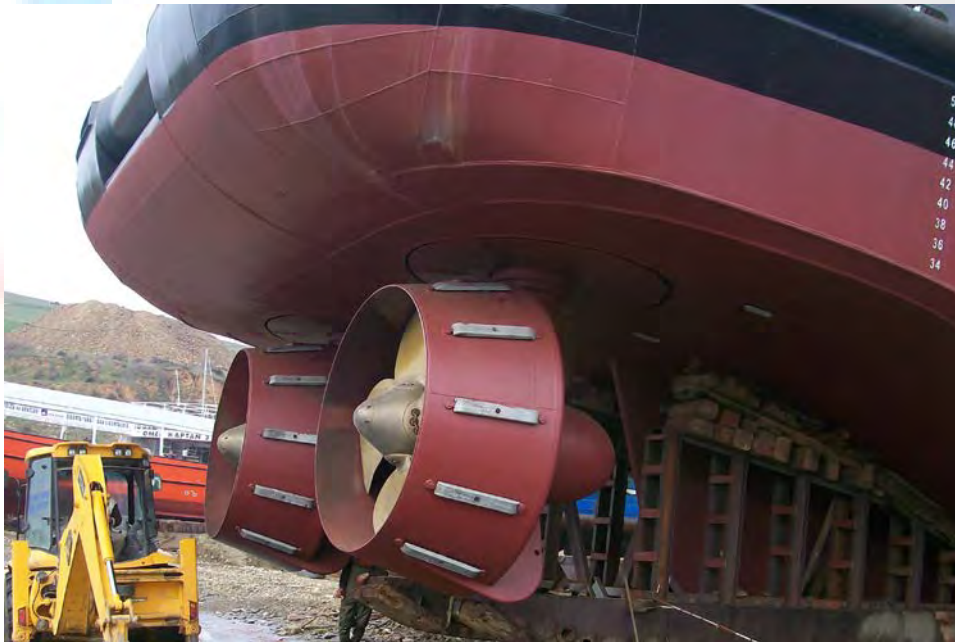

Stern View – Two(2) ASD Drives

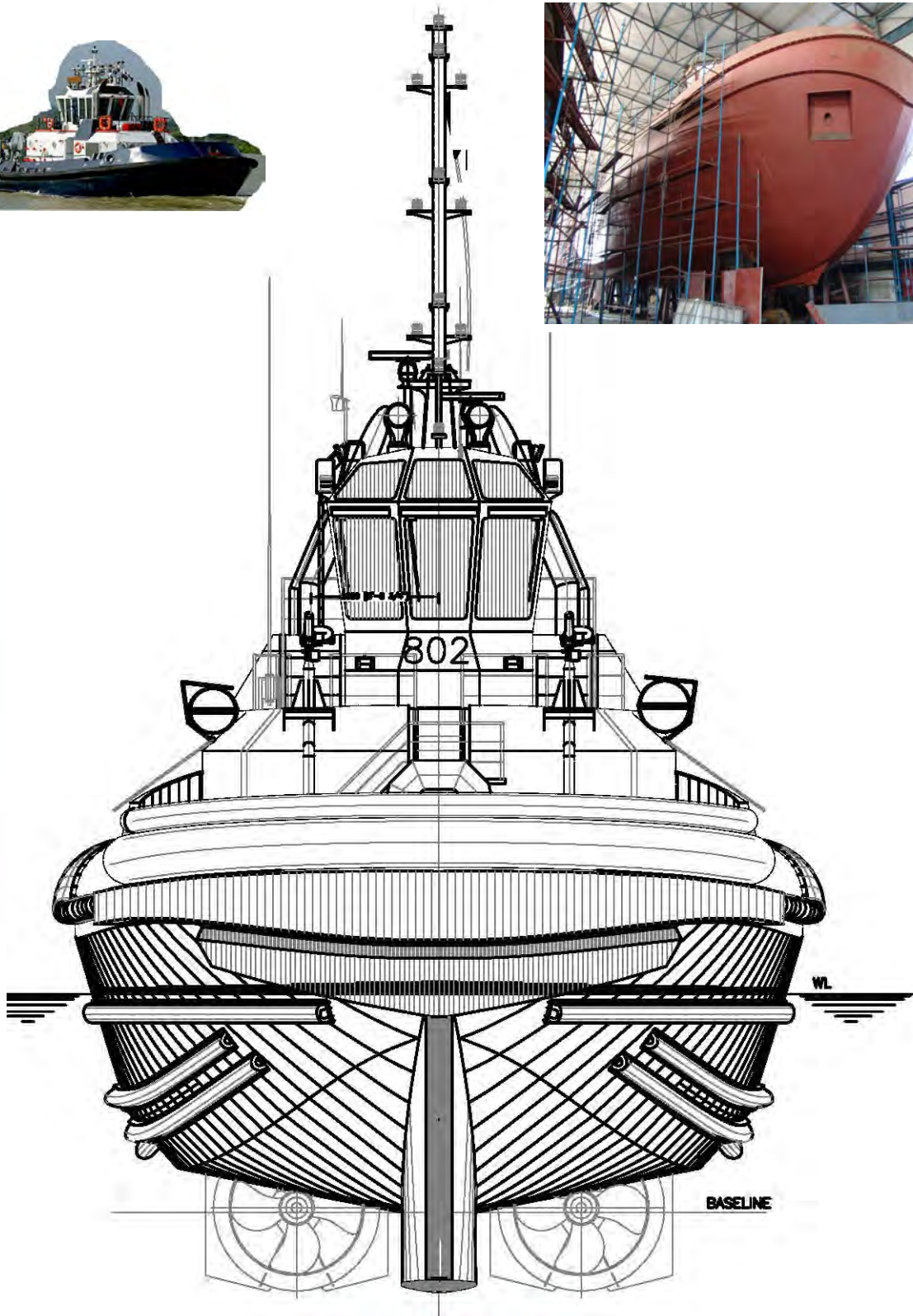

Bow View



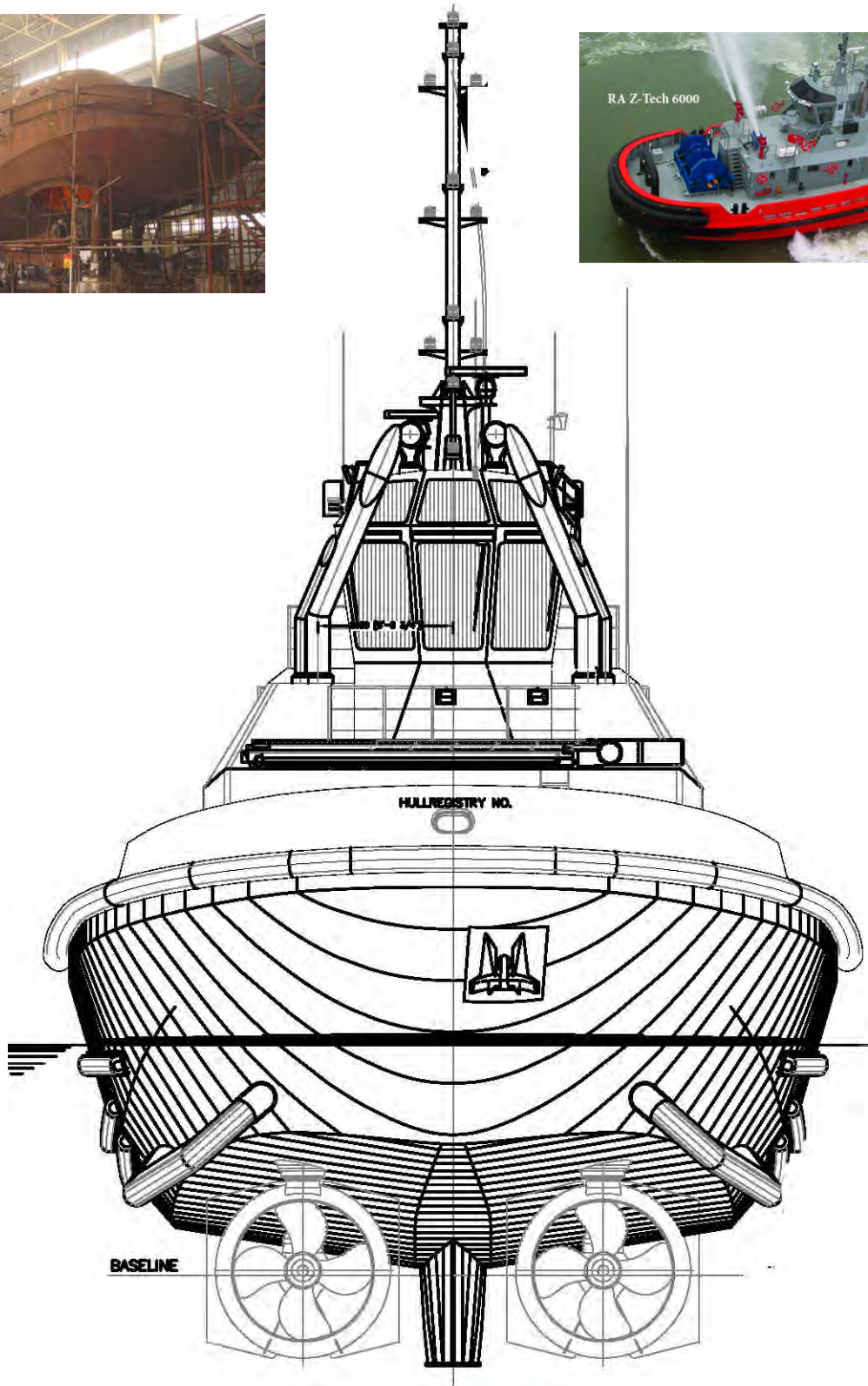

Stern View

Our Three(3) Drive Option for Greater Versatility offered in standard & Green Tug Options

A range of Rotor® tugs for various purposes have been developed, ranges from 45 tons bollard pull and ends (for now) at 120 tons bollard pull. For the LNG terminals, FSO and FPSO assisting tugs, the designers have developed a special 38+ meters 80/100 + tons bollard pull escort terminal tug with deck cargo, fuel & potable water tanks, sufficient accommodation and bunker capacities to operate in remote areas. Her three legged propulsion configuration in combination with three main engines or six(6) generators with electric drives makes the Rotor® tug one of the most reliable and powerful terminal tugs available on the market.

The Rotor® tugs, type RT-45 / RT-60 / RT-80 are modern high performance tugs specifically designed for harbour- and coastal berthing operations as well as coastal towing.



The RT-100E and the FPSO Support RT are the latest developments in the Rotor® tug range.

The patented Rotor tug propulsion configuration consists of three diesel or electric driven azimuthing thrusters, which are placed in a triangle. Thanks to this propulsion configuration the tug features extremely high manoeuvrability and enables safe towing and pushing over the bow, the stern and sideways. The special towing mode, called Rotoring is very useful in confined spaces as locks and bridges.

All the Rotor® tug designs represent a high level of practical and theoretical knowledge and have been developed in close consultation with tugboat crews and technical staff. As a result of this approach, the Rotor® tugs are safe, operational friendly and has low maintenance.

RT60-28

The Rotor® tug, type RT-60 is a modern high performance tug specifically designed for harbour- and coastal berthing operations as well as coastal towing.



Dimensions

| | | |
|----------------------|-------|--------|
| Length overall | 28.30 | metres |
| Length wl. | 26.10 | metres |
| Beam, overall | 11.70 | metres |
| Depth | 5.24 | metres |
| Draught, max. | 5.90 | metres |
| Displacement approx. | 550 | T |

Performance

| | | |
|--------------------------|------|-------|
| Power (approx.) | 4050 | kW |
| Free running speed (max) | 12.0 | knots |
| Bollard Pull | 63+ | T |

The Rotor® tug, type RT80-28 is a modern high performance tug specifically designed for harbour- and coastal berthing operations as well as coastal towing.



Dimensions

| | | |
|----------------------|-------|--------|
| Length overall | 28.30 | metres |
| Length wl. | 26.10 | metres |
| Beam, overall | 12.00 | metres |
| Depth | 5.24 | metres |
| Draught, max. | 5.95 | metres |
| Displacement approx. | 650 | T |

Performance

| | | |
|--------------------------|------|-------|
| Power | 4800 | kW |
| Free running speed (max) | 12.0 | knots |
| Bollard Pull | 80+ | T |



RT80-32

The Rotor® tug, type RT-80-32 is a modern high performance tug specifically designed for harbour- and coastal berthing operations as well as coastal towing.



Dimensions

| | | |
|------------------|-------------|--------|
| Length overall | 31.63 | metres |
| Beam, moulded | 12.00 | metres |
| Depth, moulded | 4.40 / 5.40 | metres |
| Draught, moulded | 3.86 | metres |
| Draught, average | 5.90 | metres |
| Tonnage gross | 449 | T |
| Tonnage nett | 134 | T |

Performance

| | | |
|--------------------------|------|-------|
| Power | 4700 | kW |
| Free running speed (max) | 12.5 | knots |
| Bollard Pull | 80+ | T |

ART110-37

This Escort Rotor tug design will have such a high performance and versatility that she will be unique in her market. She can be utilized for all the tasks required of such a tug supporting modern LNG Terminals. Oil Terminals and other operations where the Escort capability will be required including Oil recovery and Pollution control, Firefighting etc.



The hull form for the ART110-37 E basically derived from the existing Rotor ® tugs. In order to achieve a desired maximum trial speed of 15 knots several actions are taken: the lines plan is partially adjusted, a specially designed bulbous bow is installed and the docking stools will be removable or not installed. The hull form is characterized by sharp bilges and straight frames. The rise of floor allows sideways movements. Parallel skegs will be fitted for directional stability.



In order to control the breaking forces and steering capacities of the tug much better whilst performing escort services KST has developed an innovative feature to assure this. A special winch configuration is used to enhance the course stability of the tug and a so called retractable skeg for controlled escorting will be installed. All these features were tested in the facilities of Force Danmark and proven results are far above expectations, namely the achieved steering force of not less than 160 tons by 10 knots speed in the indirect mode makes her the escort tug of the future.

The vessel is suited to accommodate a crew of 8 (+3) persons.

The Vessel is designed to obtain at least the following notation + 1A1,Tug, EO, Ice C, SF, OILREC, FiFi 1, Escort (150/10)

Dimensions (approximately)

| | | |
|---------------------------|-------|--------|
| Length overall | 37.00 | metres |
| Length wl. | 34.10 | metres |
| Beam, moulded | 14.00 | metres |
| Depth, moulded | 6.25 | metres |
| Draught, design | 7.20 | metres |
| Light ship weight approx. | 1048 | T |
| Displacement approx. | 1478 | T |

Performance (approximately)

| | | |
|------------------|-------|-------|
| Power (Total) | 7,000 | kW |
| Max. trial speed | 15.0 | knots |
| Bollard Pull | 110 | T |

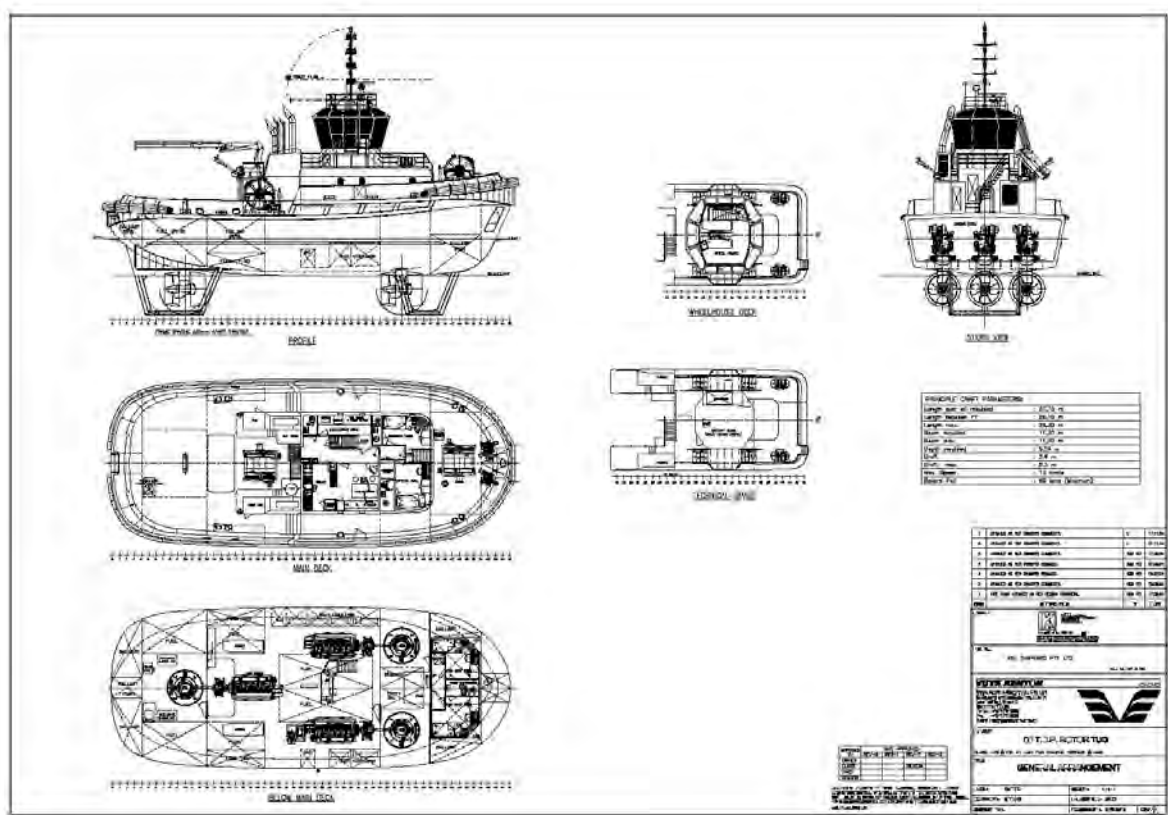

Endurance to 4000Miles

Note:- ROTOR®TUG is the registered trademark of KST BV.

For more information on RotorTug please contact our company at enquiries@aluminumnow.com



34.60m Water Tractor Tug – 70T BP

Voith Water Tractor 70 t BP

Technical Data

Main Particulars

| | |
|-------------------|---------|
| Length, o.a. | 34.60 m |
| Length, waterline | 32.00 m |
| Breadth moulded | 12.80 m |
| Draught max. | 6.61 m |
| Displacement | 1,100 t |

Speed and Bollard Pull

| | |
|--------------|------------|
| Speed | 13.5 knots |
| Bollard Pull | 70 t |

Tank Capacities

| | |
|-----------------|-------|
| Freshwater | 19 t |
| Fuel oil | 240 t |
| Lubrication oil | 9 t |
| Foam | 23 t |

Propulsion

Voith Schneider Propeller
2 x 32R5EC/265-2 with Voith Roll
Stabilization (optional)

Classification

The vessel's hull, machinery and outfitting can be classed by any recognized Classification Society. Special attention was paid to cover the following notations:

- unattended machinery space
- ice strengthening
- fire fighting 1

Accommodation

The vessel has been designed to offer room for up to 10 people. The crew is accommodated in two single and four double cabins. All cabins are equipped with separate sanitary facilities. Further spaces are designated for mess room, galley and changing room/laundry.

Machinery

| | |
|-------------------|-----------------------------|
| Main engines | 2 x 2,640 kW |
| Auxiliary engines | 2 x 163 kW |
| Emergency engine | 1 x 100 kW |
| FiFi pumps | 2 x 1,200 m ³ /h |

Due to the modular engine room concept several types of main engines can be arranged.



4

Call us today for your Tug, AHTS or other requirements

Note:- 1)The technical information and drawings are the property of the Naval Architects concerned
2)Information found here has been sourced from Public Sites or from companies concerned and is supplied for your information. Interested parties are advised to carry-out their own research and due-diligence.